

NET230N

Universal control panel for 230V operators

Operating instructions and warnings

Index

| | | | | | |
|------------|---------------------------------|----|----------|-------------------------------|----|
| 1 | Warnings Summary | 41 | 5 | Advanced programming | 75 |
| 2 | Product Description | 42 | 6 | Messages shown on the Display | 80 |
| 3 | Technical data | 42 | 7 | Installation Test | 80 |
| 4 | Configurations | 43 | 8 | Product Disposal | 80 |
| 4.1 | Sliding gates | 45 | | | |
| 4.2 | Swing gates | 51 | | | |
| 4.3 | Overhead doors | 57 | | | |
| 4.4 | Barriers | 63 | | | |
| 4.5 | Sectional Doors (Not available) | 69 | | | |

1 WARNINGS SUMMARY

Read these warnings carefully; failure to respect the following warnings may cause risk situations.

⚠ WARNING Using this product under unusual conditions not foreseen by the manufacturer can create situations of danger, and for this reason all the conditions prescribed in these instructions must be respected.

⚠ WARNING DEA System reminds all users that the selection, positioning and installation of all materials and devices which make up the complete automation system, must comply with the European Directives 2006/42/CE (Machinery Directive), 2004/108/CE (electromagnetic compatibility), 2006/95/CE (low voltage electrical equipment). In order to ensure a suitable level of safety, besides complying with local regulations, it is advisable to comply also with the above mentioned Directives in all extra European countries.

⚠ WARNING Under no circumstances must the product be used in explosive atmospheres or surroundings that may prove corrosive and damage parts of the product.

⚠ WARNING To ensure an appropriate level of electrical safety always keep the 230V power supply cables apart (minimum 4mm in the open or 1 mm through insulation) from low voltage cables (motors power supply, controls, electric locks, aerial and auxiliary circuits power supply), and fasten the latter with appropriate clamps near the terminal boards.

⚠ WARNING All installation, maintenance, cleaning or repair operations on any part of the system must be performed exclusively by qualified personnel with the power supply disconnected working in strict compliance with the electrical standards and regulations in force in the nation of installation.

⚠ WARNING Using spare parts not indicated by **DEA** System and/or incorrect re-assembly can create risk to people, animals and property and also damage the product. For this reason, always use only the parts indicated by **DEA** System and scrupulously follow all assembly instructions.

⚠ WARNING Incorrect assessment of the impact forces can cause serious damage to people, animals or things. **DEA** System reminds the installer must verify that the impact forces, measured as indicated by the standard EN 12445, are actually below the limits set by the standard EN12453.

⚠ WARNING The compliance of the internal sensing obstacles device to requirements of EN12453 is guaranteed only if used in conjunction with motors fitted with encoders.

⚠ WARNING Any external security devices used for compliance with the limits of impact forces must be conform to standard EN12978.

♻ WARNING In compliance with EU Directive 2002/96/EC on waste electrical and electronic equipment (WEEE), this electrical product should not be treated as municipal mixed waste. Please dispose of the product and bring it to the collection for an appropriate local municipal recycling.

2 PRODUCT DESCRIPTION

NET230N is a universal control panel for **DEA** System 1 or 2 230V operators automations with or without encoder.

The main feature of this control board is its ease of configuration of inputs and outputs according to any needs thus ensuring adaptability to any type of automation. It is therefore easy to set up and exclude all unnecessary functions.

3 TECHNICAL DATA

| | NET230N |
|---|--|
| Power supply (V) | 230 V ~ ±10% (50/60 Hz) |
| Fuse F2 (A) | 5A |
| Fuse F1 (A) | 160mA |
| Outputs 230V motors (maximum output current) (A) | 2 x 600W |
| Auxiliaries power supply output | +24 V === max 200mA |
| "Warning" output | 230 V ~ max 2x 40W |
| Electric lock output | max 1 art. 110 or 24V === output max 5W configurable |
| 230V Flashing light output | 230 V ~ max 40W |
| 24V Flashing light output | 24 V === max 100mA (per lampeggiante a led) art. LED24AI |
| Operating temperature range (°C) | -20 ÷ 50 °C |
| Receiver frequency | 433,92 MHz |
| Transmitters type of coding | HCS fix-code - HCS rolling code - Dip-switch |
| Max remote controllers managed | 100 |

CONFIGURATION OF THE CONTROL PANEL

The universal control unit NET230N can be used for the management of the following types (TYPE) of closures motorized by DEA System: swing and sliding gates, overhead doors and barriers.

In order to ensure maximum adaptability to each TYPE of closure, the control board provides an initial procedure, performed only at the first turn, for the optimal configuration of inputs, outputs and parameters (see diagram A). Once configured, the control panel will operate in the mode "dedicated" to the TYPE of selected closing. After performing the initial configuration it is sufficient to execute the standard programming for the installation on which it is operating.

All settings remain in memory even in the case of subsequent flare-ups (see diagram B).
If necessary the TYPE of configured closing can be later adjusted following diagram C.

FIRST CONTROL BOARD IGNITION

Configuration after the first ignition

A For the first control panel ignition, proceed as follows:

1. Apply power, the display shows in sequence the writing "rES-" and "TYPE" flashing;
2. Press the OK button and hold for 5 seconds until the display shows 0000 on the display;
3. Acting on the + and - keys, select the desired configuration depending on the type of installation (es. 0002) and confirm by pressing the OK button;
At this point, the selection will be stored and reloaded each time in the future.
4. Follow signs, "TYPE", "-00-" followed by the symbol of closed gate "----".

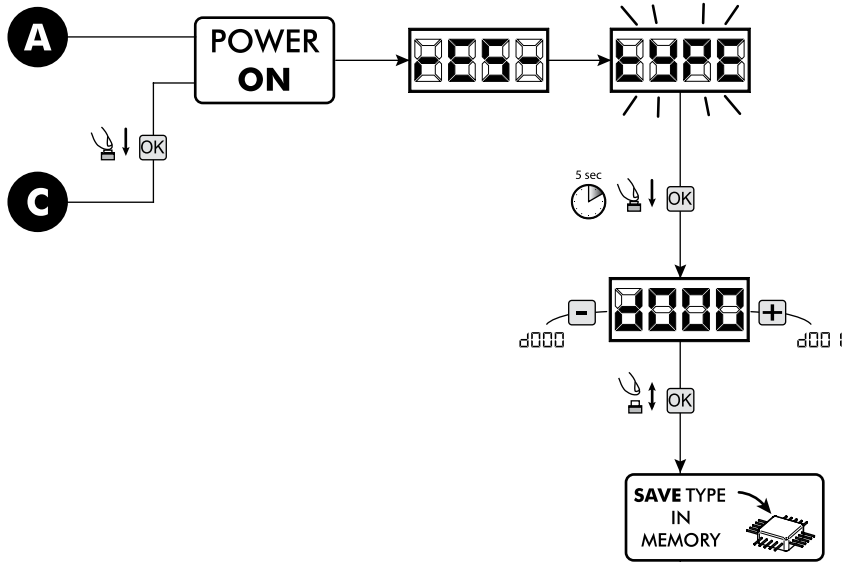

Following ignitions

B If you have already saved a configuration, proceed as follows:

Apply power, the display shows in sequence the writing "rES-", "TYPE", "-00-" followed by the symbol of closed gate "----".

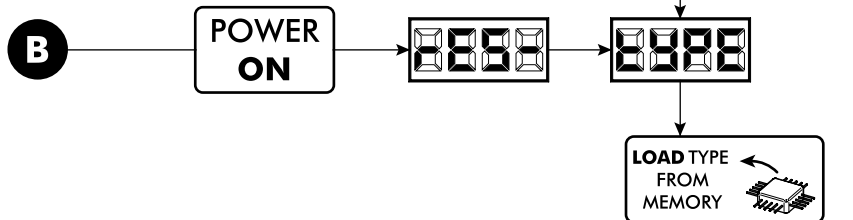

Modify the existing configuration

C If you have already saved a configuration and you want to change it, proceed as follows:

1. Hold down the OK button and give power, the display shows in sequence the writing "rES-" and "TYPE" flashing;
2. Press the OK button and hold for 5 seconds until the display shows 0000 (the value changes to match the previous configuration used) on the display;
3. Acting on the + and -, select the new desired configuration depending on the type of installation (es. 0002) and confirm by pressing the OK button;

⚠ Stop the reconfiguration procedure prior to confirmation, involves loading the previous configuration by the control panel without any modification.

⚠ However, if the reconfiguration procedure is brought to an end, the new configuration will take the place of the previous one and will be reloaded each time in the future.

4. Follow signs, "TYPE", "-00-" followed by the symbol of closed gate "----".

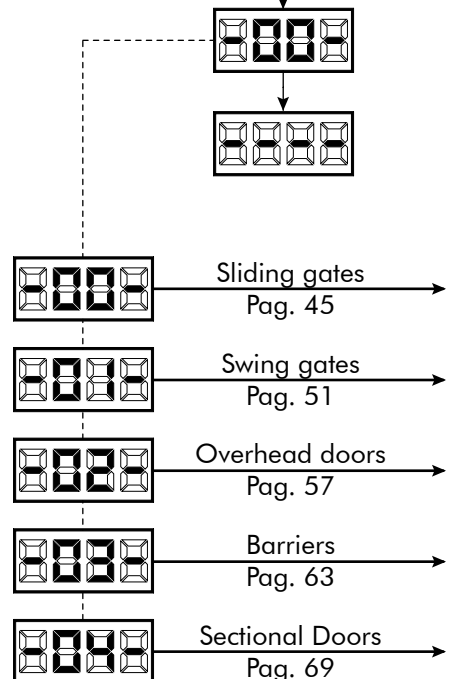

To the Standard Programming

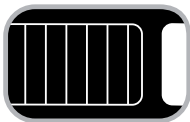

4.1 SLIDING GATES CONFIGURATION

ELECTRICAL CONNECTIONS

Execute the wiring following the directions of table 1 and diagrams on page 46.

Table 1 "terminal board connections"

| | | | |
|-------|--|---|---|
| 1-2 | | 230 V ~ ±10% (50/60 Hz) power supply input | |
| 3-4-5 | | Operator 1 output 230 V ~ max 600W | |
| 6-7-8 | | Operator 2 output 230 V ~ max 600W (if present) | |
| 9-10 | | 230 V ~ max 100 W output for open gate warning light (if P052=0) or courtesy light (if P052>1) | |
| 11-12 | | Flashing light output 230 V ~ max 40W | |
| 13-14 | | Electric-lock output max 1 art. 110 (if P062=0) or 24V === output max 5W configurable (if P062≠0) | |
| 15-16 | | Led flashing light output max 1 art. LED24AI (24 V === max 100 mA) | |
| 17-18 | | 17 - N.C. 18 - Com | <p>If the installation requires different commands and / or additional to the standard, you can configure each input to the required rate.</p> <p>Refer to Chapter "Advanced Programming".</p> |
| 19-20 | | 19 - N.C. 20 - Com | |
| 21-22 | | 21 - N.C. 22 - Com | |
| 23-24 | | 23 - N.C. 24 - Com | |
| 25-26 | | 25 - N.O. 26 - Com | |
| 27-28 | | 27 - N.O. 28 - Com | |
| 29 | | Aerial signal input | |
| 30 | | Ground aerial input | |
| 31-32 | | +24 V === power supply output for auxiliary devices 200mA | |



شرکت طرح و مهندسی آرماسیستم
 www.ArmaSystem.com
 www.CameraDoor.com

OPEN GATE WARNING LIGHT
 230V max 40W

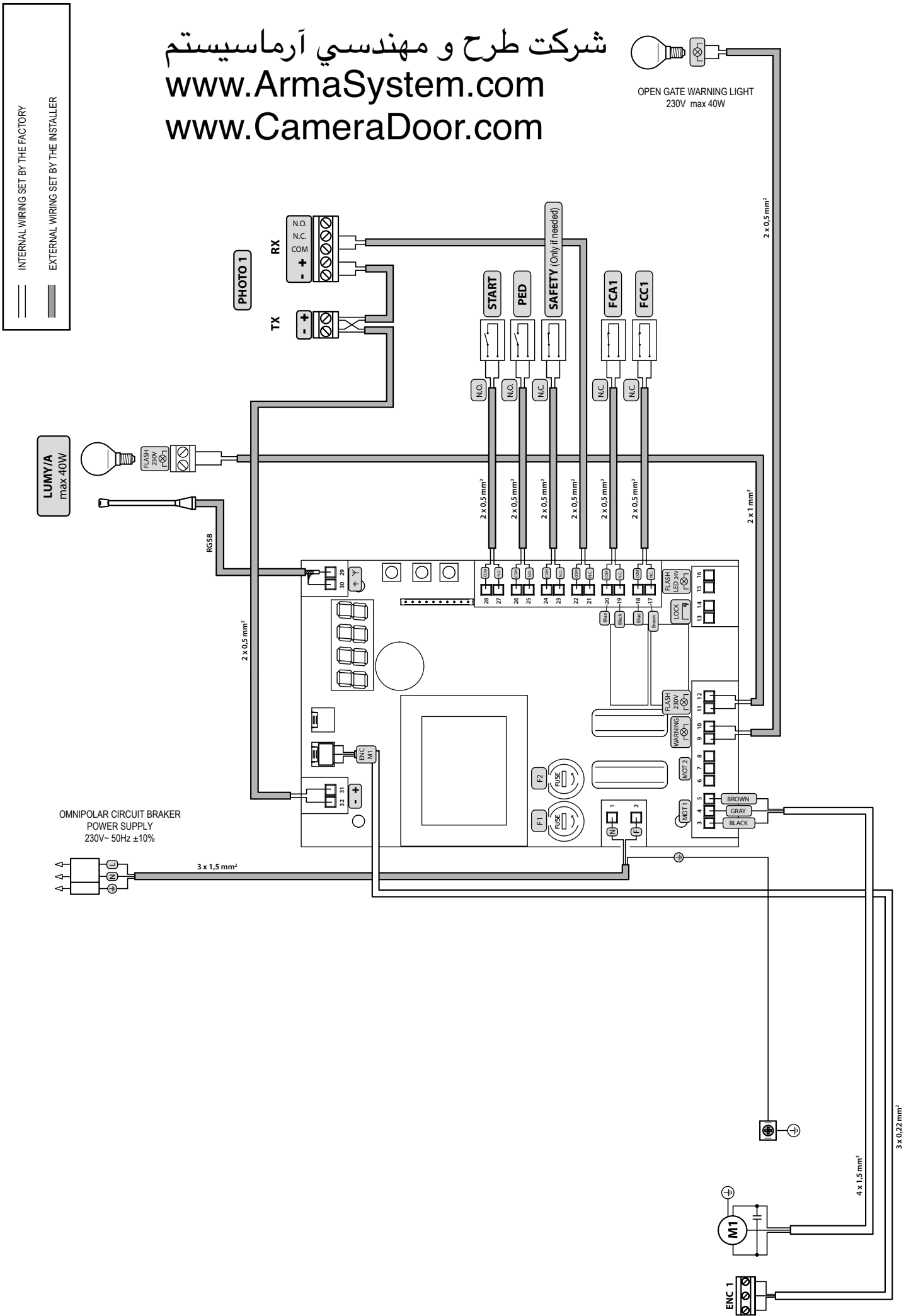

STANDARD PROGRAMMING

1 Power Supply

Give power supply, the display shows the following symbols "rES-", "TYPE", "-00-" and then "----".



* If the control panel has already been programmed and the power fails or is switched off - once power is returned and a START command is given, the position reset procedure is performed (see "rESP" in the table "WORKING STATUS MESSAGES" on page 80).

2 Visualisation of inputs and operations-counter status

1. Press the **OK** key for 15 seconds;

2. The display will show respectively:

Inputs status (check it's correct);

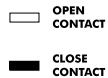

Total operations counter (* see P064):

i.g.: $\square\square\square\square = 3 \times 100^* = 3000$ operations performed

Maintenance operations-counter (* see P065):

i.g.: $\square\square\square\square = 5 \times 500 = 2500$ operations remaining before the maintenance intervention request ($\square\square\square\square =$ manoeuvres-counter disabled)

3. Hold down the **OK** key to display a cyclic 3 options, or release the **OK** button to exit the parameter.

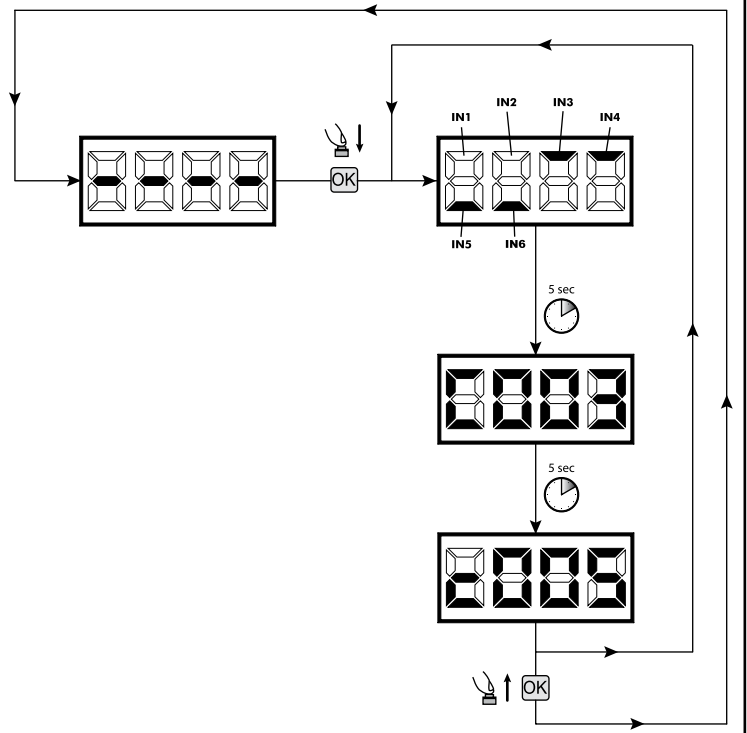

3 Selection type of operators

! IMPORTANT !

1. Scroll down the parameters with **+** and **-** keys until you visualise P028;
2. Access the parameter by pressing the **OK** key;
3. Acting on **+** and **-** keys, set:
 - d005=LIVI 6RR;
 - d006=LIVI 9RR;
 - d007=GULLIVER / REV;
4. Confirm your choice by pressing the **OK** key (display returns again to P028).

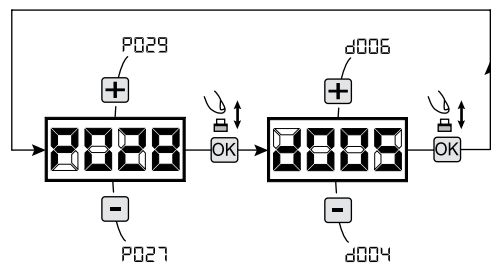

4 Selection operating with or without encoder

! IMPORTANT !

1. Scroll down the parameters with **+** and **-** keys until you visualise P029;
2. Access the parameter by pressing the **OK** key;
3. Acting on **+** and **-** keys, set:
 - d000=for operators with encoder;
 - d001=for operators without encoder;
4. Confirm your choice by pressing the **OK** key (display returns again to P029).

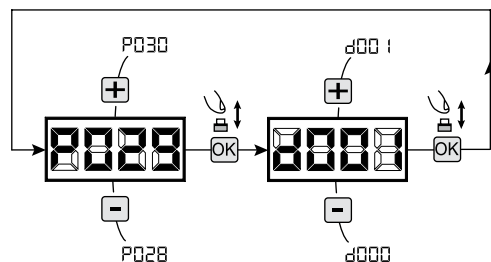

5 Selection of direction of motion

1. Scroll down the parameters with **+** and **-** keys until you visualise P063;
2. Access the parameter by pressing the **OK** key;
3. Acting on **+** and **-** keys, set:
 - d000=motor in standard position (on the left of the gap);
 - d001=motor in inverted position (on the right of the gap);
4. Confirm your choice by pressing the **OK** key (display returns again to P063).

Warning: The parameter automatically reverses the motors output open/close and any limit switch input open/close.

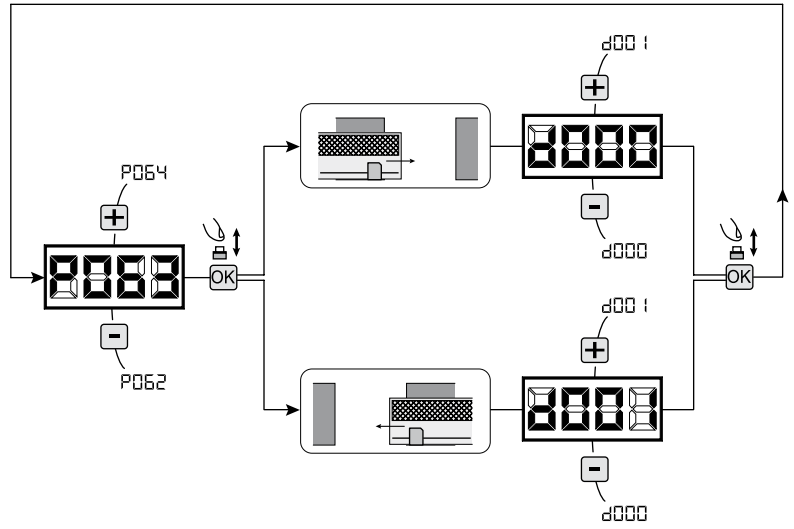

6 Motor stroke learning

1. Scroll down the parameters with **+** and **-** keys until you visualise P003;
2. Access the parameter by pressing the **OK** key;
3. When "PPP" flashes, continue pressing the **OK** key;
4. Release the **OK** key when "PPP" stops flashing; the learning procedure starts;
5. Wait for the door searches and stops on the opening stop and then on the closing stop.
If you want to anticipate the stopping strokes in opening, you can manually intervene by giving an impulse to "Start" button (or pressing the "OK" on the control panel) simulating the stroke.
6. Once the procedure is ended, the display will show "----".

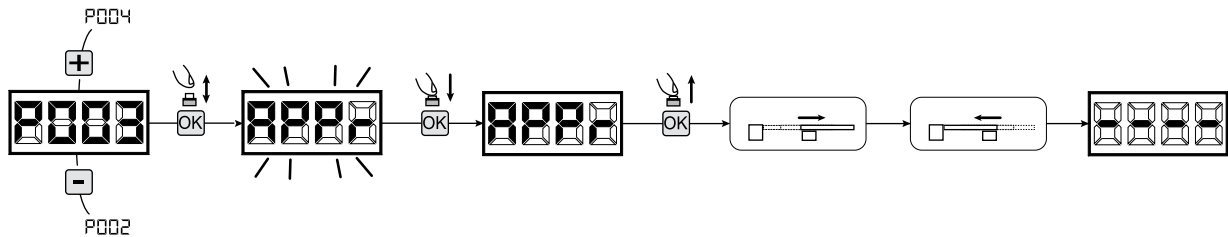

7 Transmitters learning

7.1 Transmitters coding selection

1. Scroll down the parameters with **+** and **-** keys until you visualise P027;
2. Confirm by pressing on the **OK** key;
3. Select the type of transmitter by scrolling **+** and **-** keys:
 - d000=fix rolling-code (**suggested**);
 - d001=complete rolling-code;
 - d002=dip-switch;
4. Confirm by pressing on the **OK** key (display shows again P027).

Warning: If you need to vary the type of encoding, and only if other remotes with different encoding are memorized, you need to erase memory (P004) **AFTER** you have set the new encoding.

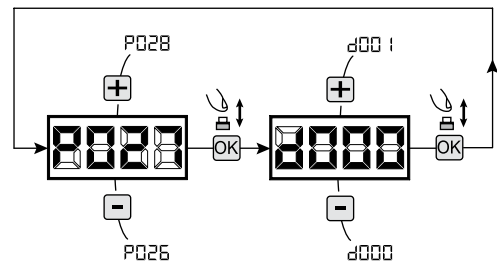

7.2 Learning

1. Scroll down the parameters with **+** and **-** keys until you visualise P005;
2. Confirm by pressing on the **OK** key;
3. When the symbol "LEARN" flashes, press on any key of the transmitter you want to memorize;
4. The display visualizes the number of the transmitter just memorized and then "LEARN" flashing;
5. Memorize all necessary transmitters repeating this procedure from step 3;
6. Wait 10 seconds before quitting the memorization mode, display shows now "----".

Warning: In the case of rolling code remotes, the receiver can be put into learning mode by pressing the hidden button on a remote control previously learned.

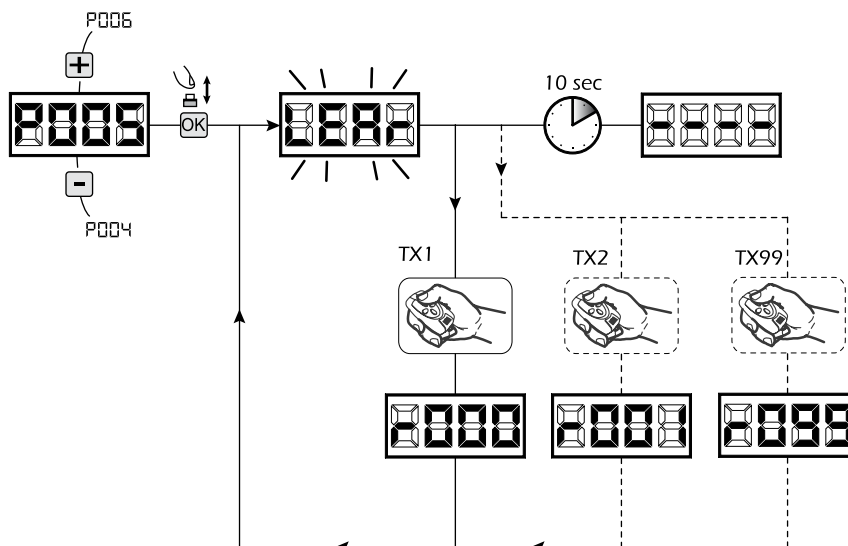

8 Adjustment of operating parameters

If you need to modify the operating parameters (force, speedness etc.):

1. Scroll down the parameters until you visualize the desired parameter (i.g. P032);
2. Confirm by pressing on the **OK** key;
3. By pressing on **+** and **-**, set up the desired value;
4. Confirm by pressing on the **OK** key (display shows the parameters previously selected).

For the complete list of the "Operating Parameters" See the table on page 78.

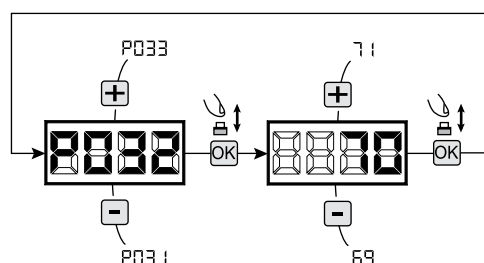

9 Programming complete

WARNING At the end of the programming procedure, use the buttons **+** and **-** until the appearance of the symbol "----", the operator is now ready again for new manoeuvres.

To perform any "Advanced Programming" operations (cancellation of the remotes, configuration inputs, etc. ..), see on page 75.





4.2 SWING GATES CONFIGURATION

ELECTRICAL CONNECTIONS

Execute the wiring following the directions of table 1 and diagrams on page 52.

Table 1 "terminal board connections"

| | | | |
|-------|--|---|---|
| 1-2 | | 230 V ~ ±10% (50/60 Hz) power supply input | |
| 3-4-5 | | Operator 1 output 230 V ~ max 600W | |
| 6-7-8 | | Operator 2 output 230 V ~ max 600W (if present) | |
| 9-10 | | 230 V ~ max 100 W output for open gate warning light (if P052=0) or courtesy light (if P052>1) | |
| 11-12 | | Flashing light output 230 V ~ max 40W | |
| 13-14 | | Electric-lock output max 1 art. 110 (if P062=0) or 24V === output max 5W configurable (if P062≠0) | |
| 15-16 | | Led flashing light output max 1 art. LED24AI (24 V === max 100 mA) | |
| 17-18 | | 17 - N.C. | Input 6 STOP. In case of intervention, it stops the movement of both motors during any operation. If unused, short circuit. |
| | | 18 - Com | |
| 19-20 | | 19 - N.C. | Input 5 PHOTO 2. When enabled (see parameter P051 in the table), activation of PHOTO 2 provokes: an inversion of direction (during closing), the arrest of the movement (during opening), prevent the start (gate closed). If unused, short circuit. |
| | | 20 - Com | |
| 21-22 | | 21 - N.C. | Input 4 PHOTO 1. When enabled (see parameter P050 in the table), activation of PHOTO 1 provokes: an inversion of direction (during closing), the arrest of the movement (during opening), prevent the start (gate closed). If unused, short circuit. |
| | | 22 - Com | |
| 23-24 | | 23 - N.C. | Input 3 SAFETY. If activated, it causes the inversion. See P055 and P056 on the parameters table. If unused, short circuit. |
| | | 24 - Com | |
| 25-26 | | 25 - N.O. | Input 2 PED. If activated, it opens motor nr. 1 only. |
| | | 26 - Com | |
| 27-28 | | 27 - N.O. | Input 1 START. In case of intervention it provokes: the operator opening or closing. It may operate as "inversion" mode (P49=0) or "step by step" mode (P49=1). |
| | | 28 - Com | |
| 29 | | Aerial signal input | |
| 30 | | Ground aerial input | |
| 31-32 | | +24 V === power supply output for auxiliary devices 200mA | |

If the installation requires different commands and / or additional to the standard, you can configure each input to the required rate.

Refer to Chapter "Advanced Programming".



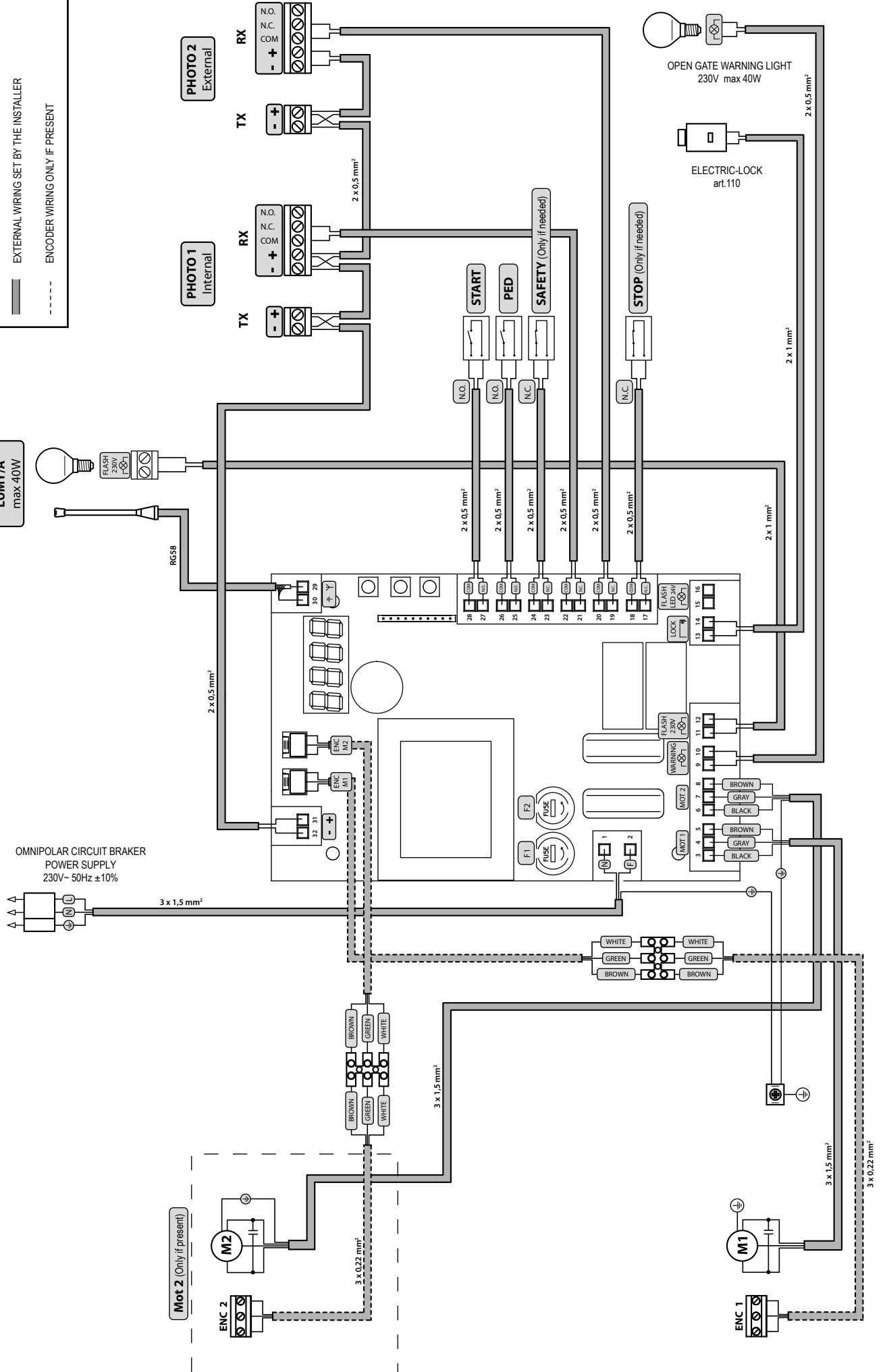

STANDARD PROGRAMMING

1 Power Supply

Dare alimentazione, sul display compaiono in sequenza le scritte "rES-", "TYPE", "-0 1-" seguite dal simbolo di cancello chiuso "----"

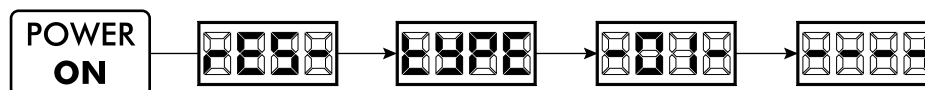

* If the control panel has already been programmed and the power fails or is switched off - once power is returned and a START command is given, the position reset procedure is performed (see "rESP" in the table "WORKING STATUS MESSAGES" on page 80).

2 Visualisation of inputs and operations-counter status

1. Press the **OK** key for 15 seconds;

2. The display will show respectively:

Inputs status (check it's correct);

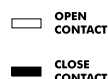

Total operations counter (* see P064):

i.g.: $\square\square\square\square = 3 \times 100^* = 3000$ operations performed

Maintenance operations-counter (* see P065):

i.g.: $\square\square\square\square = 5 \times 500 = 2500$ operations remaining before the maintenance intervention request ($\square\square\square\square =$ manoeuvres-counter disabled)

3. Hold down the **OK** key to display a cyclic 3 options, or release the **OK** button to exit the parameter.

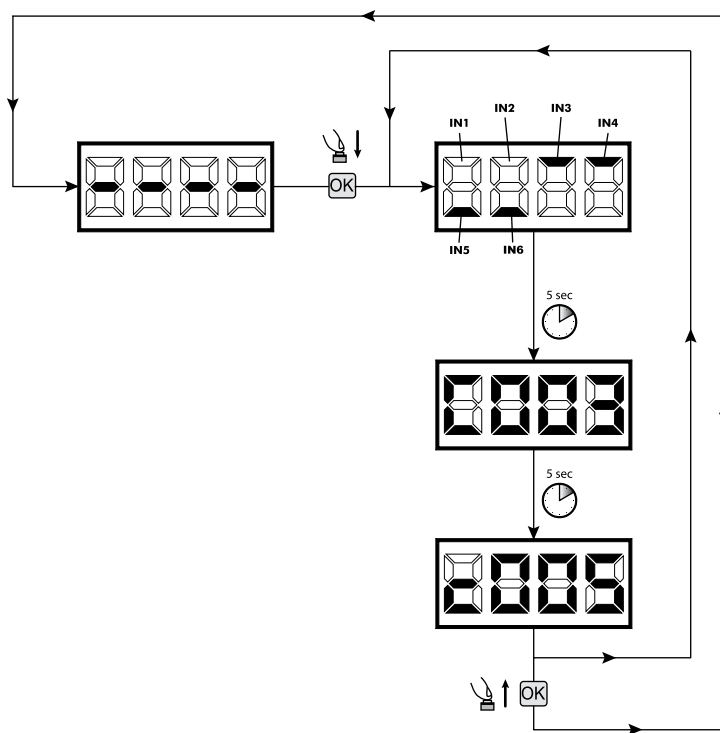

3 Selection type of operators

! IMPORTANT !

1. Scroll down the parameters with **+** and **-** keys until you visualise P028;
2. Access the parameter by pressing the **OK** key;
3. Acting on **+** and **-** keys, set:
 - d001=LOOK - MAC;
 - d002=GHOST;
 - d003=LIVI 500/502;
4. Confirm your choice by pressing the **OK** key (display returns again to P028).

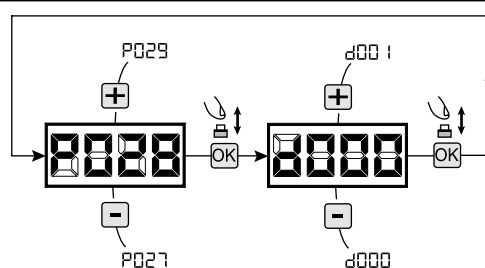

4 Selection operating with or without encoder

! IMPORTANT !

1. Scroll down the parameters with **+** and **-** keys until you visualise P029;
2. Access the parameter by pressing the **OK** key;
3. Acting on **+** and **-** keys, set:
 - d000=for operators with encoder;
 - d001=for operators without encoder;
4. Confirm your choice by pressing the **OK** key (display returns again to P029).

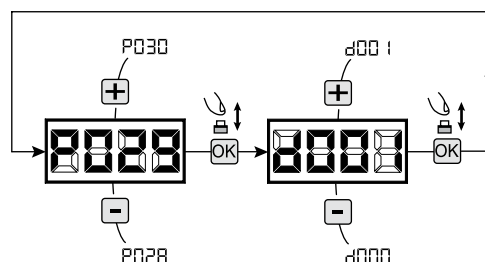

5 Selection 1 or 2 operators functioning

1. Scroll down the parameters with **+** and **-** keys until you visualise P030;
2. Access the parameter by pressing the **OK** key;
3. Acting on **+** and **-** keys, set:
 - d001=for a single motor operating;
 - d002=for 2 motors operating;
4. Confirm your choice by pressing the **OK** key (display returns again to P030).

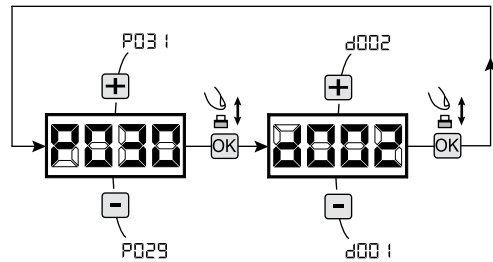

6 Motor stroke learning

1. Scroll down the parameters with **+** and **-** keys until you visualise P003;
2. Access the parameter by pressing the **OK** key;
3. When "RRRr" flashes, continue pressing the **OK** key;
4. Release the **OK** key when "RRRr" stops flashing; the learning procedure starts;
5. Wait for the door (or doors in case of using 2 motors) searches and stops on the opening stop and then on the closing stop. If you want to anticipate the stopping strokes in opening, you can manually intervene by giving an impulse to "Start" button (or pressing the "OK" on the control panel) simulating the stroke.
6. Once the procedure is ended, the display will show "----".

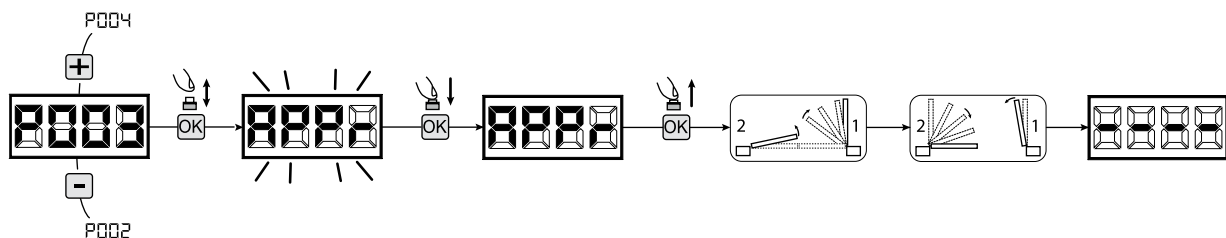

7 Transmitters learning

7.1 Transmitters coding selection

1. Scroll down the parameters with **+** and **-** keys until you visualise P027;
2. Confirm by pressing on the **OK** key;
3. Select the type of transmitter by scrolling **+** and **-** keys:
 - d000=fix rolling-code (**suggested**);
 - d001=complete rolling-code;
 - d002=dip-switch;
4. Confirm by pressing on the **OK** key (display shows again P027).

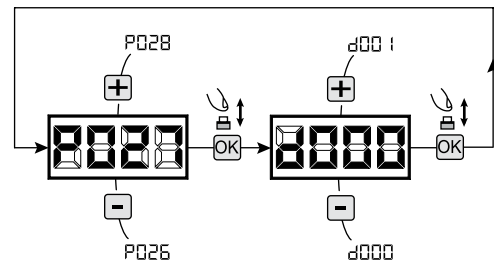

Warning: If you need to vary the type of encoding, and only if other remotes with different encoding are memorized, you need to erase memory (P004) **AFTER** you have set the new encoding.

7.2 Learning

1. Scroll down the parameters with **+** and **-** keys until you visualise P005;
2. Confirm by pressing on the **OK** key;
3. When the symbol "LErr" flashes, press on any key of the transmitter you want to memorize;
4. The display visualizes the number of the transmitter just memorized and then "LErr" flashing;
5. Memorize all necessary transmitters repeating this procedure from step 3;
6. Wait 10 seconds before quitting the memorization mode, display shows now "----".

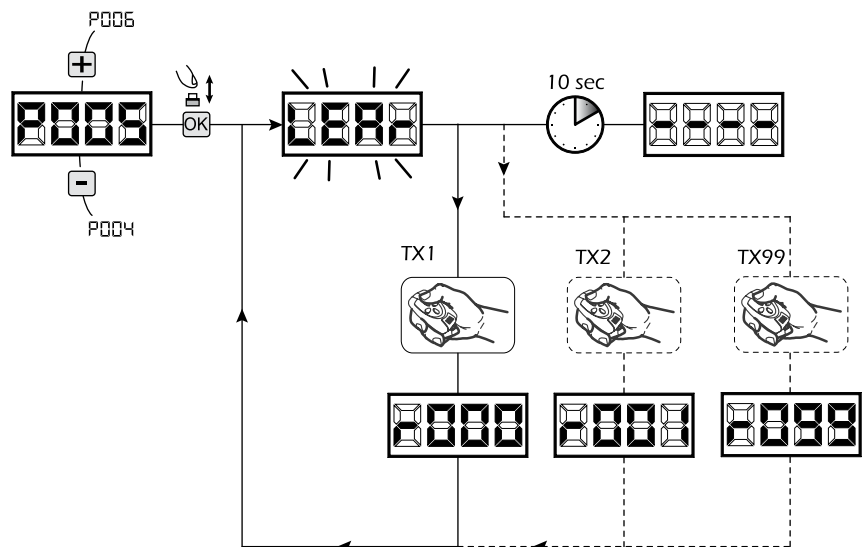

Warning: In the case of rolling code remotes, the receiver can be put into learning mode by pressing the hidden button on a remote control previously learned.

8 Adjustment of operating parameters

If you need to modify the operating parameters (force, speedness etc.):

1. Scroll down the parameters until you visualize the desire parameter (i.g. P032);
2. Confirm by pressing on the **OK** key;
3. By pressing on **+** and **-**, set up the desired value;
4. Confirm by pressing on the **OK** key (display shows the parameters previously selected).

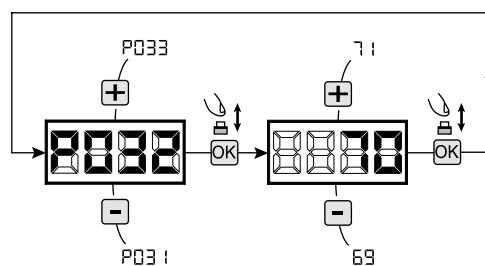

For the complete list of the "Operating Parameters" See the table on page. 78.

9 Programming complete

WARNING At the end of the programming procedure, use the buttons **+** and **-** until the appearance of the symbol "----", the operator is now ready again for new manoeuvres.

To perform any "Advanced Programming" operations (cancellation of the remotes, configuration inputs, etc. ..), see on page 75.





4.3 OVERHEAD DOORS CONFIGURATION

ELECTRICAL CONNECTIONS

Execute the wiring following the directions of table 1 and diagrams on page 58.

Table 1 "terminal board connections"

| | | | |
|-------|-----------|---|--|
| 1-2 | | 230 V ~ ±10% (50/60 Hz) power supply input | |
| 3-4-5 | | Operator 1 output 230 V ~ max 600W | |
| 6-7-8 | | Operator 2 output 230 V ~ max 600W (if present) | |
| 9-10 | | 230 V ~ max 100 W output for open gate warning light (if P052=0) or courtesy light (if P052>1) | |
| 11-12 | | Flashing light output 230 V ~ max 40W | |
| 13-14 | | Electric-lock output max 1 art. 110 (if P062=0) or 24V === output max 5W configurable (if P062≠0) | |
| 15-16 | | Led flashing light output max 1 art. LED24AI (24 V === max 100 mA) | |
| 17-18 | 17 - N.O. | Input 6. Unused. | If the installation requires different commands and / or additional to the standard, you can configure each input to the required rate. Refer to Chapter "Advanced Programming". |
| | 18 - Com | | |
| 19-20 | 19 - N.O. | Input 5. Unused. | |
| | 20 - Com | | |
| 21-22 | 21 - N.C. | Input 4 STOP. In case of intervention, it stops the movement of both motors during any operation. If unused, short circuit. | |
| | 22 - Com | | |
| 23-24 | 23 - N.C. | Input 3 SAFETY. If activated, it causes the inversion. See P055 and P056 on the parameters table. If unused, short circuit. | |
| | 24 - Com | | |
| 25-26 | 25 - N.C. | Input 2 PHOTO 1. When enabled (see parameter P050 in the table), activation of PHOTO 1 provokes: an inversion of direction (during closing), the arrest of the movement (during opening), prevent the start (gate closed). If unused, short circuit. | |
| | 26 - Com | | |
| 27-28 | 27 - N.O. | Input 1 START. In case of intervention it provokes: the operator opening or closing. It may operate as "inversion" mode (P49=0) or "step by step" mode (P49=1). | |
| | 28 - Com | | |
| 29 | | Aerial signal input | |
| 30 | | Ground aerial input | |
| 31-32 | | +24 V === power supply output for auxiliary devices 200mA | |



INTERNAL WIRING SET BY THE FACTORY
 EXTERNAL WIRING SET BY THE INSTALLER

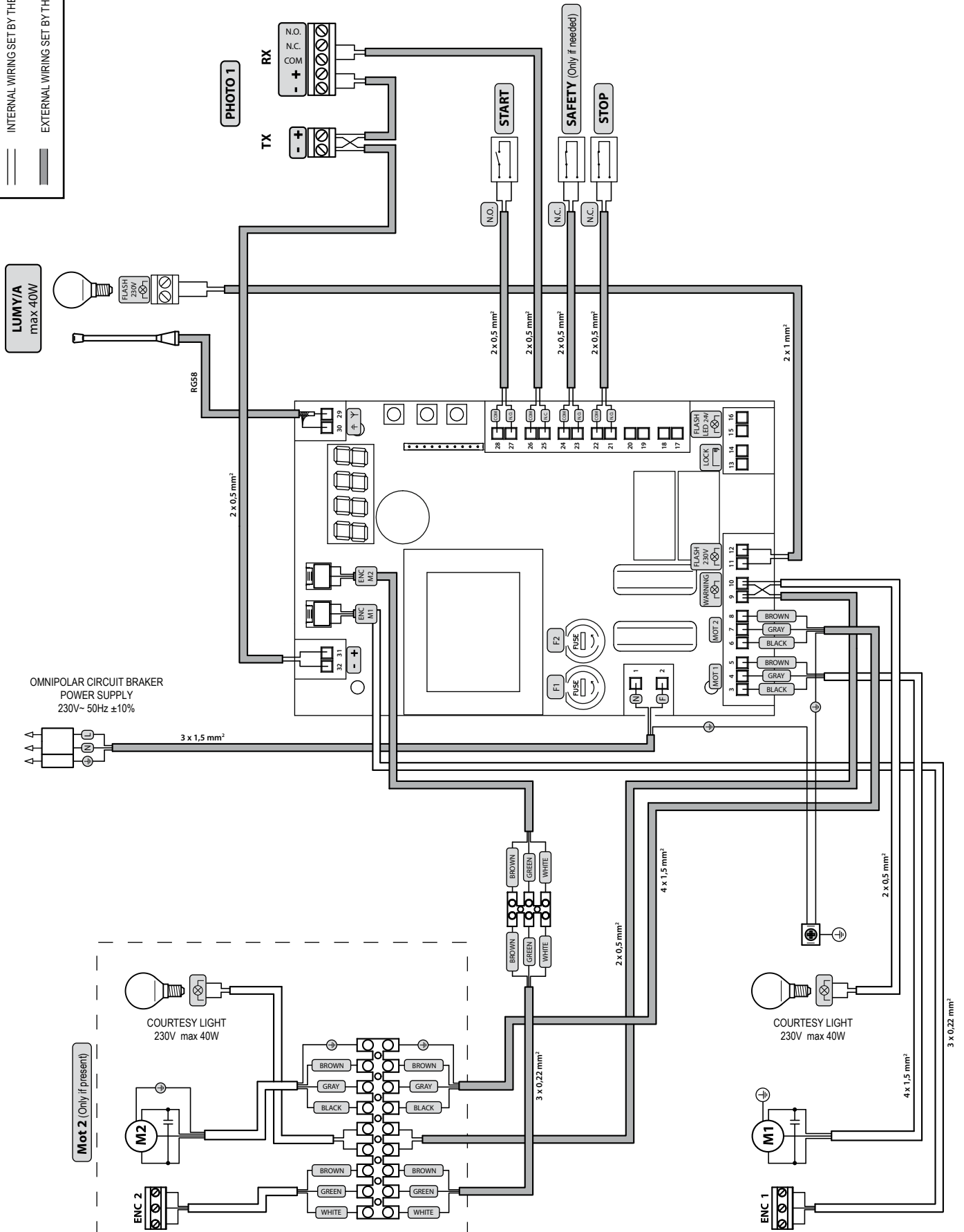

STANDARD PROGRAMMING

1 Power Supply

Give power supply, the display shows the following symbols "rES-", "TYPE", "-02-" and then "----".



* If the control panel has already been programmed and the power fails or is switched off - once power is returned and a START command is given, the position reset procedure is performed (see "rESP" in the table "WORKING STATUS MESSAGES" on page 80).

2 Visualisation of inputs and operations-counter status

1. Press the **OK** key for 15 seconds;

2. The display will show respectively:

Inputs status (check it's correct);



Total operations counter (* see P064):

i.g.: $\square\square\square\square = 3 \times 100^* = 3000$ operations performed

Maintenance operations-counter (* see P065):

i.g.: $\square\square\square\square = 5 \times 500 = 2500$ operations remaining before the maintenance intervention request ($\square\square\square\square =$ manoeuvres-counter disabled)

3. Hold down the **OK** key to display a cyclic 3 options, or release the **OK** button to exit the parameter.

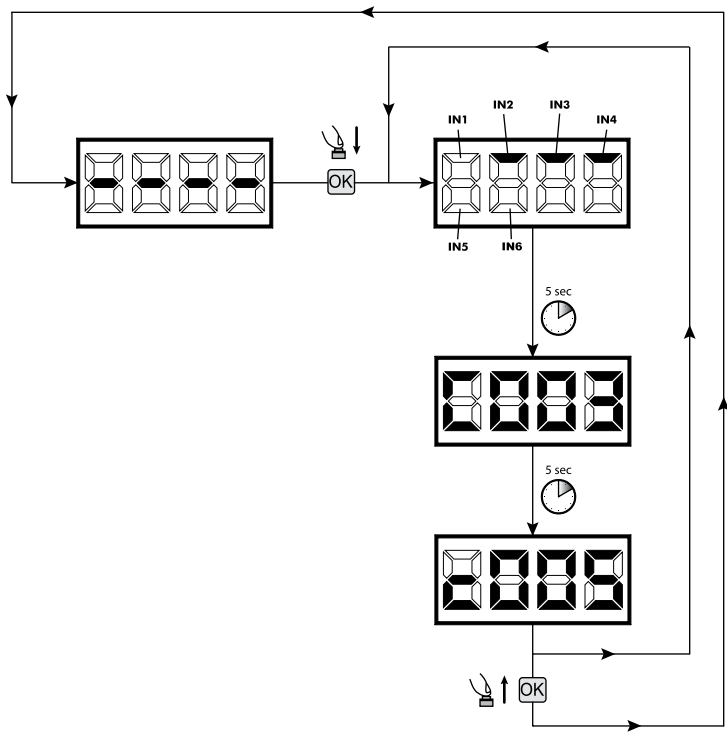

3 Selection operating with or without encoder

! IMPORTANT !

1. Scroll down the parameters with **+** and **-** keys until you visualise P029;
2. Access the parameter by pressing the **OK** key;
3. Acting on **+** and **-** keys, set:
 - d000=for operators with encoder;
 - d001=for operators without encoder;
4. Confirm your choice by pressing the **OK** key (display returns again to P029).

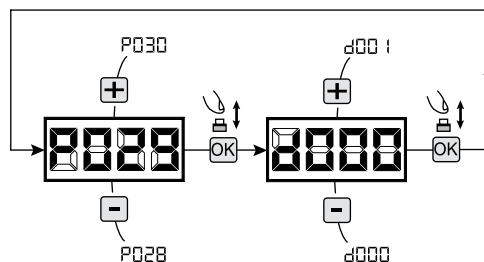



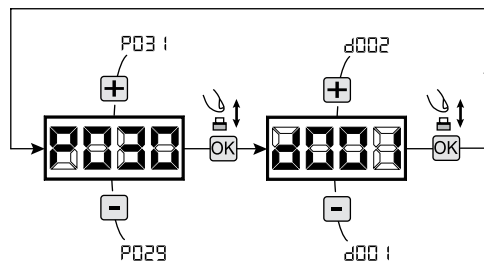

4 Selection 1 or 2 operators functioning

1. Scroll down the parameters with **+** and **-** keys until you visualise P030;
2. Access the parameter by pressing the **OK** key;
3. Acting on **+** and **-** keys, set:
 - d001=for a single motor operating;
 - d002=for 2 motors operating;
4. Confirm your choice by pressing the **OK** key (display returns again to P030).



7 Adjustment of operating parameters

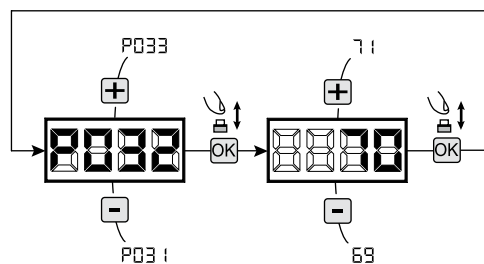

If you need to modify the operating parameters (force, speedness etc..):

1. Scroll down the parameters until you visualize the desire parameter (i.g. P032);
2. Confirm by pressing on the  key;
3. By pressing on  and , set up the desired value;
4. Confirm by pressing on the  key (display shows the parameters previously selected).



For the complete list of the "Operating Parameters" See the table on page. 78.

8 Programming complete

WARNING At the end of the programming procedure, use the buttons  and  until the appearance of the symbol "----", the operator is now ready again for new manoeuvres.

To perform any "Advanced Programming" operations (cancellation of the remotes, configuration inputs, etc. ..), see on page 75.





4.4 BARRIERS CONFIGURATION

ELECTRICAL CONNECTIONS

Execute the wiring following the directions of table 1 and diagrams on page 64.

Table 1 "terminal board connections"

| | | | | |
|-------|--|---|---|--|
| 1-2 | | 230 V ~ ±10% (50/60 Hz) power supply input | | |
| 3-4-5 | | Operator 1 output 230 V ~ max 600W | | |
| 6-7-8 | | Operator 2 output 230 V ~ max 600W (if present) | | |
| 9-10 | | 230 V ~ max 100 W output for open gate warning light (if P052=0) or courtesy light (if P052>1) | | |
| 11-12 | | Flashing light output 230 V ~ max 40W | | |
| 13-14 | | Electric-lock output max 1 art. 110 (if P062=0) or 24V === output max 5W configurable (if P062≠0) | | |
| 15-16 | | Led flashing light output max 1 art. LED24AI (24 V === max 100 mA) | | |
| 17-18 | | 17 - N.C. | If the installation requires different commands and / or additional to the standard, you can configure each input to the required rate. Refer to Chapter "Advanced Programming". | |
| | | 18 - Com | | Input 6 STOP. In case of intervention, it stops the movement of both motors during any operation. If unused, short circuit. |
| 19-20 | | 19 - N.O. | | Input 5 CLOSE. If it intervenes, it causes the closing maneuver. |
| | | 20 - Com | | |
| 21-22 | | 21 - N.O. | | Input 4 OPEN. If it intervenes it causes the opening maneuver. |
| | | 22 - Com | | |
| 23-24 | | 23 - N.C. | | Input 3 SAFETY. If activated, it causes the inversion. See P055 and P056 on the parameters table. If unused, short circuit. |
| | | 24 - Com | | |
| 25-26 | | 25 - N.C. | Input 2 PHOTO 1. When enabled (see parameter P050 in the table), activation of PHOTO 1 provokes: an inversion of direction (during closing), the arrest of the movement (during opening), prevent the start (gate closed). If unused, short circuit. | |
| | | 26 - Com | | |
| 27-28 | | 27 - N.O. | Input 1 START. In case of intervention it provokes: the operator opening or closing. It may operate as "inversion" mode (P49=0) or "step by step" mode (P49=1). | |
| | | 28 - Com | | |
| 29 | | Aerial signal input | | |
| 30 | | Ground aerial input | | |
| 31-32 | | +24 V === power supply output for auxiliary devices 200mA | | |



INTERNAL WIRING SET BY THE FACTORY
EXTERNAL WIRING SET BY THE INSTALLER

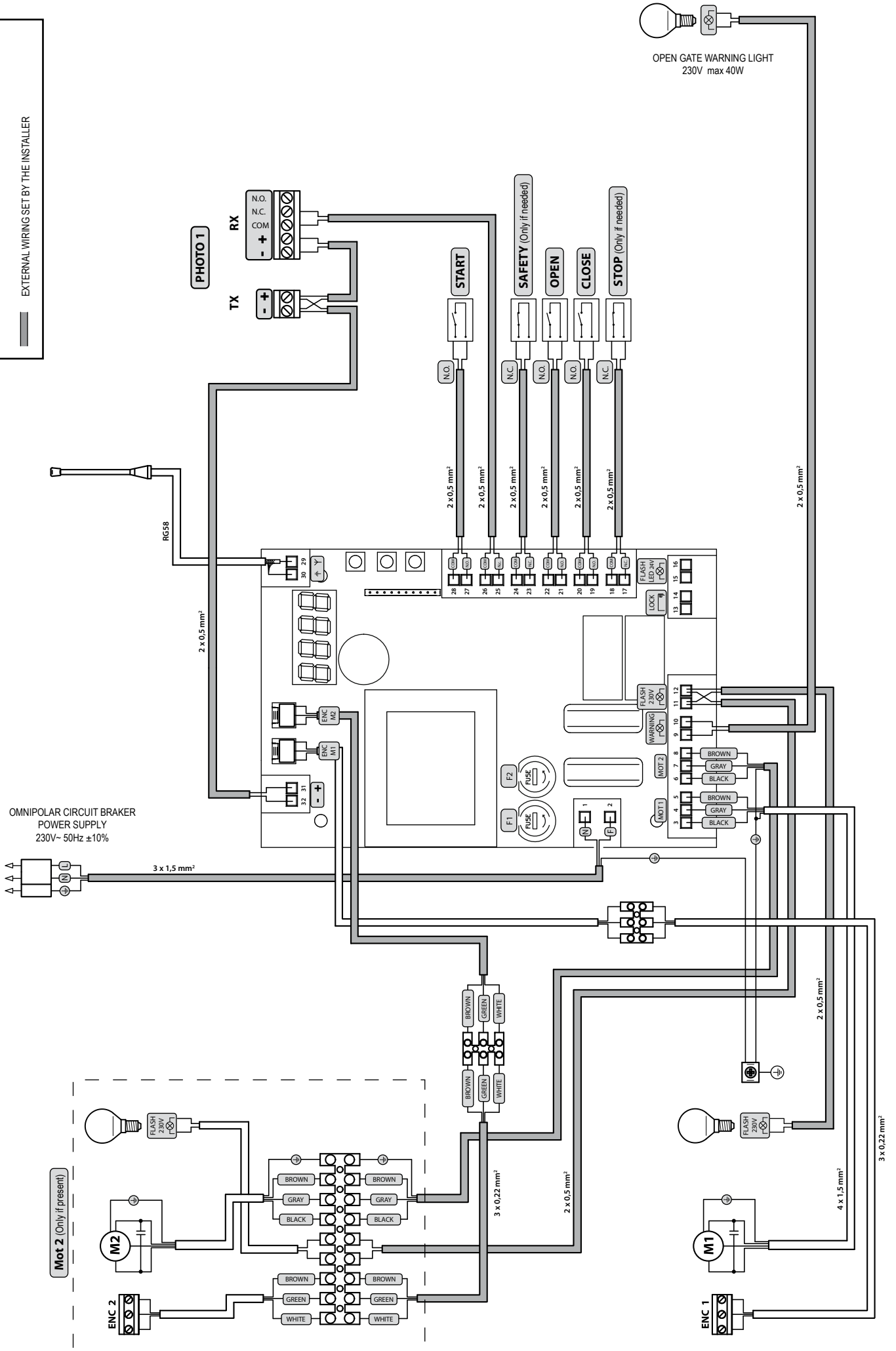

STANDARD PROGRAMMING

1 Power Supply

Give power supply, the display shows the following symbols "rES-", "TYPE", "-03-" and then "----".



* If the control panel has already been programmed and the power fails or is switched off - once power is returned and a START command is given, the position reset procedure is performed (see "rESP" in the table "WORKING STATUS MESSAGES" on page 80).

2 Visualisation of inputs and operations-counter status

1. Press the **OK** key for 15 seconds;

2. The display will show respectively:

Inputs status (check it's correct);

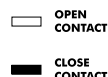

Total operations counter (* see P064):

i.g.: $\square\square\square\square = 3 \times 100^* = 3000$ operations performed

Maintenance operations-counter (* see P065):

i.g.: $\square\square\square\square = 5 \times 500 = 2500$ operations remaining before the maintenance intervention request ($\square\square\square\square =$ manoeuvres-counter disabled)

3. Hold down the **OK** key to display a cyclic 3 options, or release the **OK** button to exit the parameter.

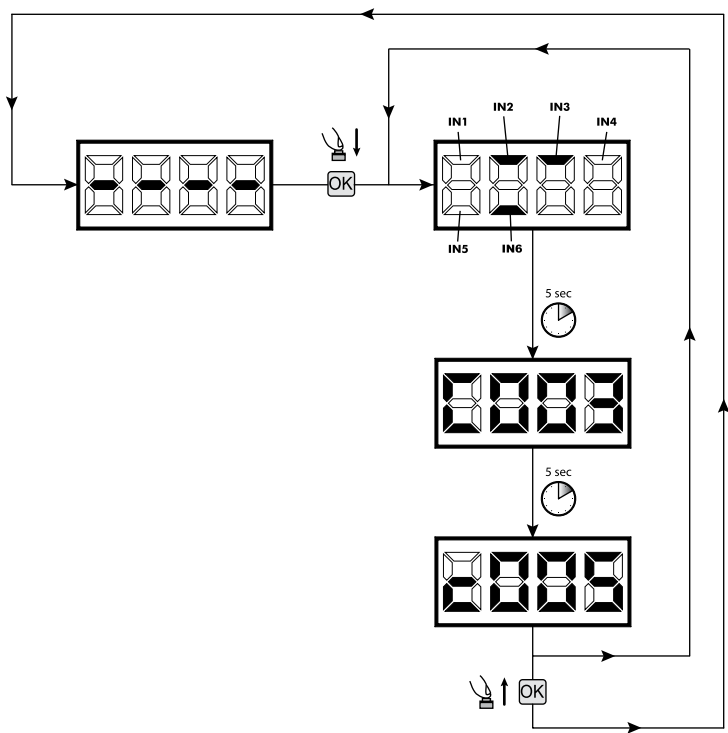

3 Selection type of operators

! IMPORTANT !

1. Scroll down the parameters with **+** and **-** keys until you visualise P028;
2. Access the parameter by pressing the **OK** key;
3. Acting on **+** and **-** keys, set:
 - d003=PASS;
 - d004=STOP;
4. Confirm your choice by pressing the **OK** key (display returns again to P028).

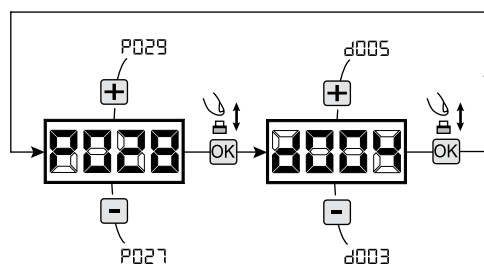

4 Selection operating with or without encoder

! IMPORTANT !

1. Scroll down the parameters with **+** and **-** keys until you visualise P029;
2. Access the parameter by pressing the **OK** key;
3. Acting on **+** and **-** keys, set:
 - d000=for operators with encoder;
 - d001=for operators without encoder;
4. Confirm your choice by pressing the **OK** key (display returns again to P029).

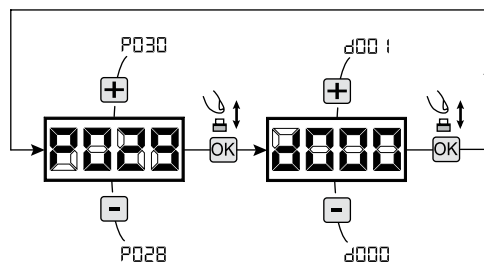

5 Selection 1 or 2 operators functioning

1. Scroll down the parameters with **+** and **-** keys until you visualise P030;
2. Access the parameter by pressing the **OK** key;
3. Acting on **+** and **-** keys, set:
 - d001=for a single motor operating;
 - d002=for 2 motors operating;
4. Confirm your choice by pressing the **OK** key (display returns again to P030).

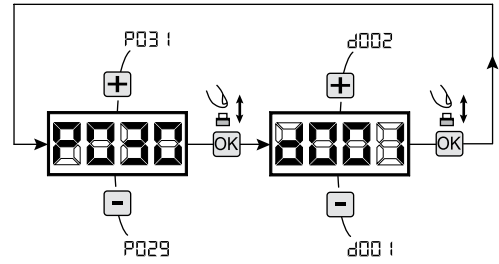

6 Selection of direction of motion

1. Scroll down the parameters with **+** and **-** keys until you visualise P063;
2. Access the parameter by pressing the **OK** key;
3. Acting on **+** and **-** keys, set:
 - d000=motor in standard position (on the right of the gap);
 - d001=motor in inverted position (on the left of the gap);
4. Confirm your choice by pressing the **OK** key (display returns again to P063).

Warning: The parameter automatically reverses the motors output open/close and any limit switch input open/close.

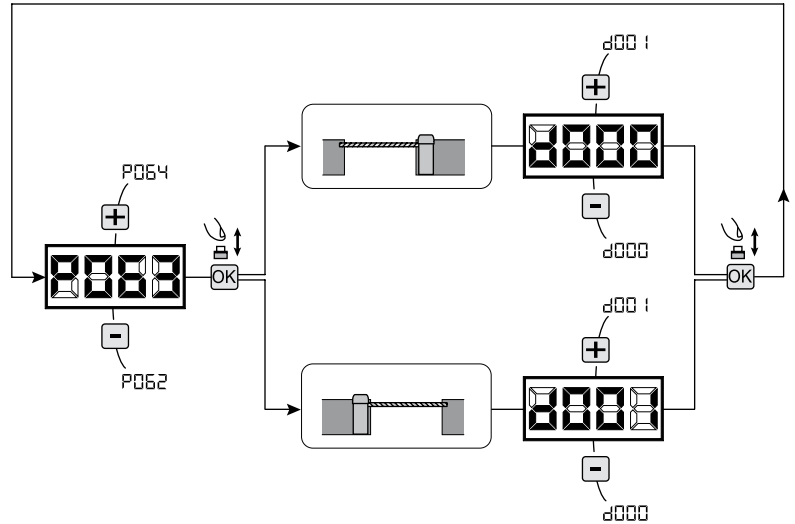

7 Motor stroke learning

1. Scroll down the parameters with **+** and **-** keys until you visualise P003;
2. Access the parameter by pressing the **OK** key;
3. When "PPP" flashes, continue pressing the **OK** key;
4. Release the **OK** key when "PPP" stops flashing; the learning procedure starts;
5. Wait for the boom (or booms if two opposite barriers) searches and stops on the opening stop and then on the closing stop. If you want to anticipate the stopping strokes in opening, you can manually intervene by giving an impulse to "Start" button (or pressing the "OK" on the control panel) simulating the stroke.
6. Once the procedure is ended, the display will show "----".

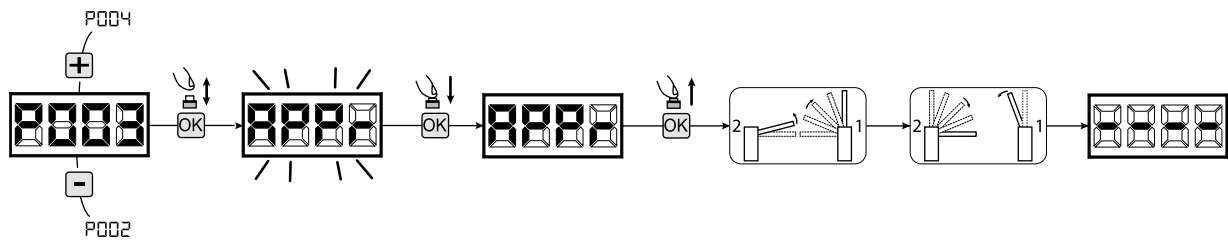

8 Transmitters learning

8.1 Transmitters coding selection

1. Scroll down the parameters with **+** and **-** keys until you visualise P027;
2. Confirm by pressing on the **OK** key;
3. Select the type of transmitter by scrolling **+** and **-** keys:
 - d000=fix rolling-code (suggested);
 - d001=complete rolling-code;
 - d002=dip-switch;
4. Confirm by pressing on the **OK** key (display shows again P027).

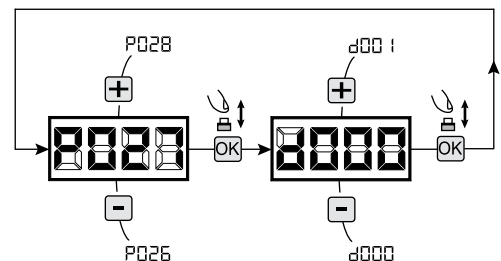

Warning: If you need to vary the type of encoding, and only if other remotes with different encoding are memorized, you need to erase memory (P004) **AFTER** you have set the new encoding.

8.2 Learning

1. Scroll down the parameters with **+** and **-** keys until you visualise P005;
2. Confirm by pressing on the **OK** key;
3. When the symbol "LEARN" flashes, press on any key of the transmitter you want to memorize;
4. The display visualizes the number of the transmitter just memorized and then "LEARN" flashing;
5. Memorize all necessary transmitters repeating this procedure from step 3;
6. Wait 10 seconds before quitting the memorization mode, display shows now "----".

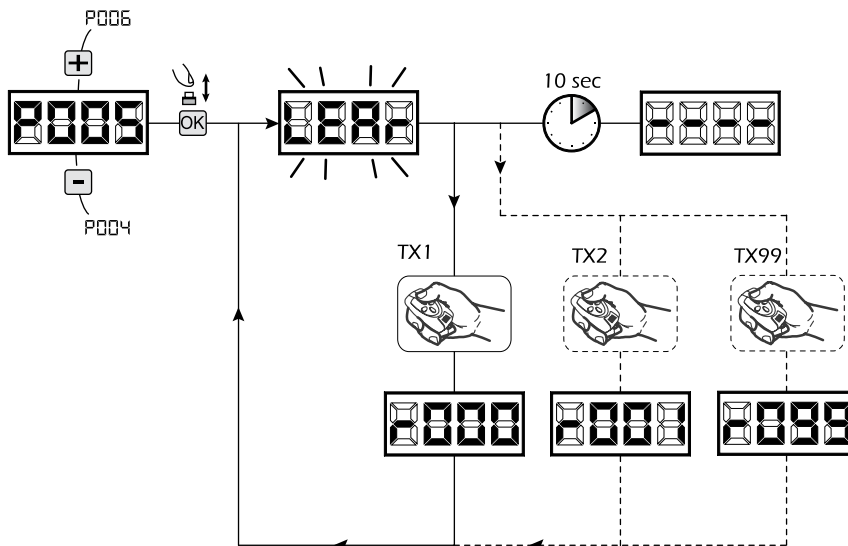

Warning: In the case of rolling code remotes, the receiver can be put into learning mode by pressing the hidden button on a remote control previously learned.

9 Adjustment of operating parameters

If you need to modify the operating parameters, follow the procedure below.

Warning: In order to ensure an optimum operation, the parameters given in the table must be set as indicated for the type of barrier used.

1. Scroll down the parameters until you visualize the desired parameter (i.g. P032);
2. Confirm by pressing on the **OK** key;
3. By pressing on **+** and **-**, set up the desired value;
4. Confirm by pressing on the **OK** key (display shows the parameters previously selected).

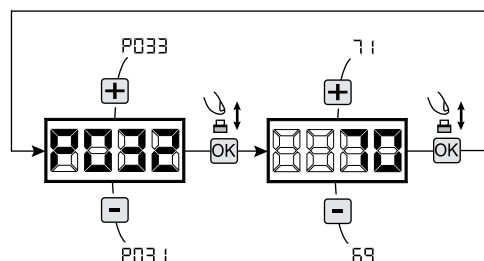

For the complete list of the "Operating Parameters" See the table on page 78.

Recommended values for standard "TYPE 03 - Barriers"

| | BOOM | Running speed (P032 - P033) | Slowdown speed (P034) | Slowdown duration (P035 - P036) | Soft-start (P054) | Facilitation release (P057) | Stop margin (P058 - P059) |
|------|----------------|-----------------------------|-----------------------|---------------------------------|-------------------|-----------------------------|---------------------------|
| STOP | STOP_L (7,5 m) | 75% | 40% | 20% | 1 | 3 | 15 |
| | STOP_L (6 m) | 85% | 30% | 20% | 1 | 3 | 15 |
| | STOP_L (5 m) | 90% | 30% | 30% | 1 | 3 | 15 |
| | STOP_L (4 m) | 100% | 25% | 20% | 0 | 2 | 15 |
| | STOP_V (4 m) | 100% | 20% | 40% | 0 | 2 | 7 |
| PASS | PASS_L (4 m) | 100% | 30% | 30% | 0 | 2 | 20 |
| | PASS_V (3 m) | 100% | 25% | 25% | 0 | 1 | 5 |
| | PASS_V (4 m) | 85% | 25% | 30% | 0 | 1 | 5 |

10 Programming complete

WARNING At the end of the programming procedure, use the buttons **+** and **-** until the appearance of the symbol "----", the operator is now ready again for new manoeuvres.

To perform any "Advanced Programming" operations (cancellation of the remotes, configuration inputs, etc. ..), see on page 75.



5 ADVANCED PROGRAMMING

Here are some added programming procedures relating to remotes memory management and advanced configuration of the control inputs.

1 Deletion of memorized transmitters

1.1 Deletion of all transmitters

1. Scroll down the parameters until you visualize P004;
2. Confirm by pressing on the **OK** key;
3. When "P004" is flashing, press the **OK** key for a few seconds;
4. Release the **OK** key as soon as "P004" stops flashing;
5. All memorized transmitters have been deleted (display shows again P004).

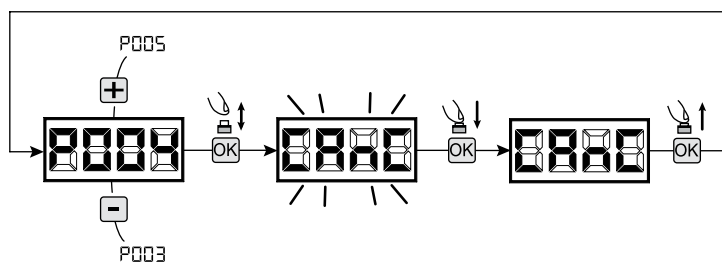

1.2 How to search and delete a transmitter

1. Scroll down the parameters until you visualize P006;
2. Confirm by pressing on the **OK** key;
3. By pressing on **+** and **-**, keys, select the transmitter you want to delete (eg. r 003);
4. When "r 003" flashes, confirm the deletion by pressing the **OK** key for a few seconds;
5. Release the **OK** key when appears "r ---";
6. The selected transmitter is deleted (display shows again P006).

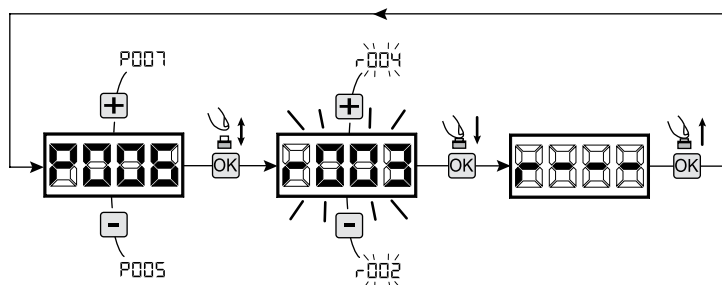

2 Resetting of default parameters

1. Scroll down the parameters until you visualize P007;
2. Confirm by pressing on the **OK** key;
3. When "dEF-" flashes, press the **OK** key;
4. Release the **OK** key as soon as "dEF-" stops flashing; Default parameters for the configuration currently in use are restored;
6. At the end of the operation display returns to P007.

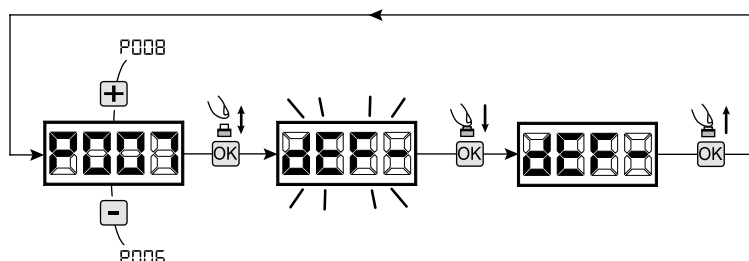

Warning: After you restore the default parameters, you must program the control panel again and adjust all operating parameters, in particular, remember to properly set the configuration of parameters (P028 - P029 - P030 - operator configuration).

3 Locking-Unlocking access to programming

By using a "dip-switch" remote (regardless of the type of remotes already memorized) it's possible to lock-unlock access to the programming of the control panel to avoid tampering. The remote setting is the locking-unlocking code verified by the control board.

3.1 Locking access to programming

1. Scroll through the parameters with the buttons **+** and **-** until the display shows P008;
2. Access the parameter by pressing the button **OK**;
3. The display shows alternately the writing P r 00 / F r EE to indicate that the control board is waiting for the transmission of the block code;
4. Within 10 seconds press CH1 on the "TX Master", the display shows P r 00 / b L O C before returning to the list of parameters;
5. Access to programming is locked.

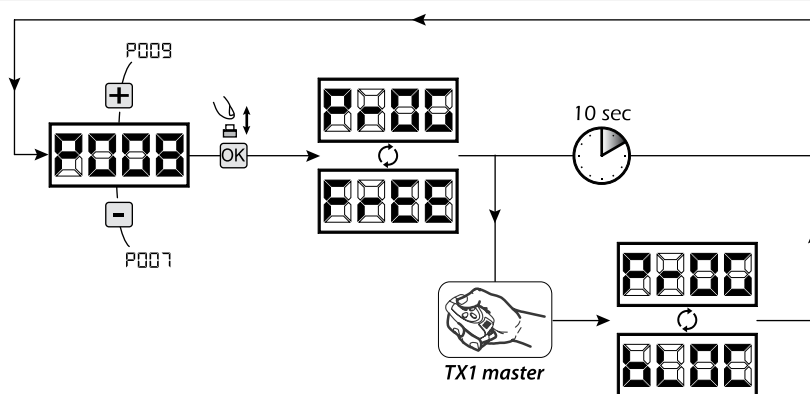

3.2 Unlocking access to programming

1. Scroll through the parameters with the buttons **+** and **-** until the display shows P008;
2. Access the parameter by pressing the button **OK**;
3. The display shows alternately the writing **Pr00/bL00** to indicate that the control board is waiting for the transmission of the unlocking code;
4. Within 10 sec. press the CH1 of the "TX Master", the display shows **Pr00/FrEE** before returning to the list of parameters;
5. Access to programming is unlocked.

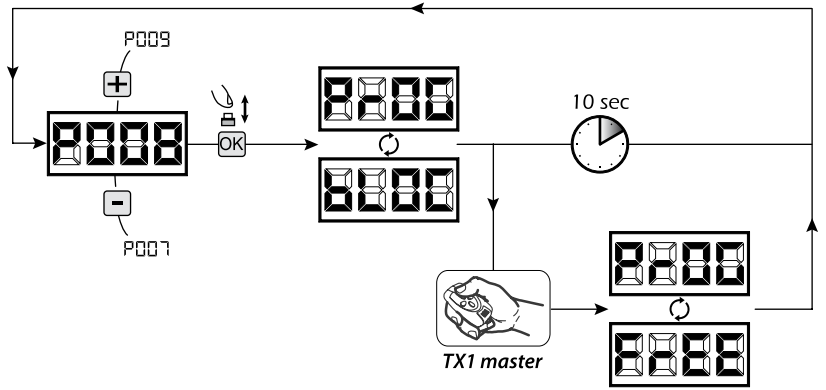

3.3 Unlocking access to programming and global reset

WARNING! This procedure involves the loss of all stored settings.

The procedure allows the unlocking of the control panel without having to know its unlocking code.

Following this release, you must program the control panel again and adjust all operating parameters, **in particular, remember to properly set the configuration of parameters (P028 - P029 - P030 - operator configuration)**. You will also need to repeat the measurement of impact forces to ensure the installation compliance to standards.

1. Scroll through the parameters with the buttons **+** and **-** until the display shows P008;
2. Access the parameter by pressing the button **OK**;
3. The display shows alternately the writing **Pr00/bL00**;
4. Press the button **OK**, the display shows the flashing writing **FrEE**;
5. Press the button again and hold for 5 seconds (releasing it before, the procedure is terminated): The display shows the fixed writing **FrEE** followed by **dEF-**, before returning to the list of parameters;
6. Access to programming is unlocked.

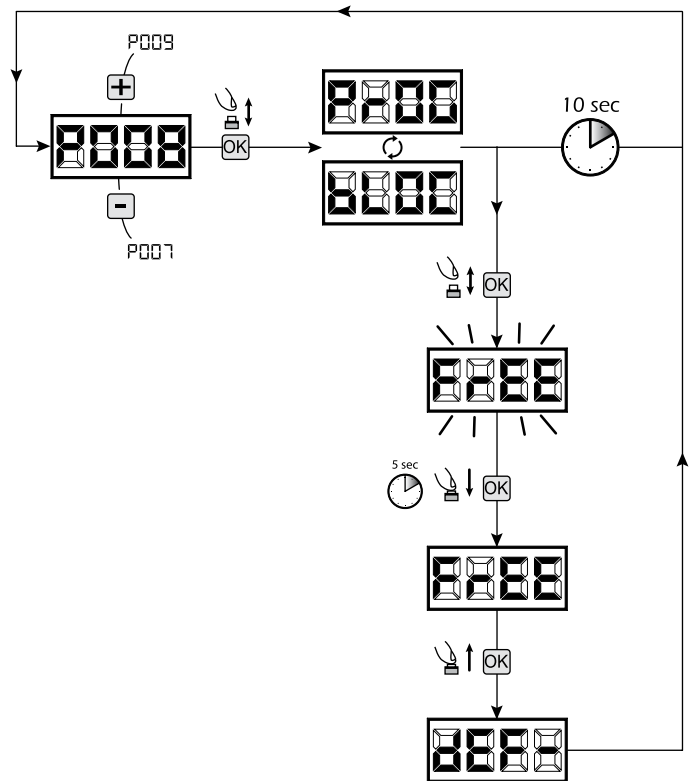

4 Inputs configuration

Where the installation requires different commands and / or additional to the standard ones described by plan, you can configure each input for the operation desired (eg START, PHOTOS, STOP, etc ...).

1. Scroll down the parameters with the **+** and **-** to see that corresponding to the desired one:
 - P017=for INPUT 1;
 - P018=for INPUT 2;
 - P019=for INPUT 3;
 - P020=for INPUT 4;
 - P021=for INPUT 5;
 - P022=for INPUT 6;
2. Confirm by pressing on the **OK** key to get access to the parameter (eg. P018);
3. Scroll down with the **+** and **-**, keys to set the value corresponding to the desired operation (refer to table "Input Configuration parameters" on page 77);
4. Confirm by pressing on the **OK** key (display shows again P018).
5. Execute the new connection to the input just reconfigured.

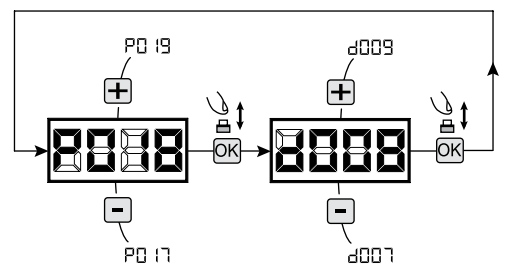

5 Programming complete

WARNING At the end of the programming procedure, use the buttons **+** and **-** until the appearance of the symbol "----", the operator is now ready again for new manoeuvres.

| PAR. | PROCEDURE | SETTABLE VALUES |
|------|--|-----------------|
| P001 | Positioning of operator 1 | |
| P002 | Positioning of operator 2 | |
| P003 | Memorization of the motors' stroke | |
| P004 | Deletion of transmitters | |
| P005 | Transmitters memorizing | |
| P006 | Search and deletion of a transmitter | |
| P007 | Loading of standard parameters: the list is up dated with factory settings | |
| P008 | Lock access to programming | |
| P009 | Unused parameter | |
| P010 | Unused parameter | |
| P011 | Unused parameter | |
| P012 | Unused parameter | |
| P013 | Unused parameter | |
| P014 | Unused parameter | |
| P015 | Unused parameter | |

PROGRAMMING PROCEDURES

| PAR. | PARAMETER DESCRIPTION | SETTABLE VALUES | DEFAULT VALUES (for different standards of installation) | | | | |
|------|------------------------------------|--|---|-----------------------|-----------------------|-----------------------|-------------------------|
| | | | DEF0 sliding gate | DEF 1 Swing gate | DEF2 overhead door | DEF3 barriera | DEF4 Sectional doors |
| P016 | INPUT_3 selectioning input type | <ul style="list-style-type: none"> • 000: IN3 type=free contact • 001: IN3 type=constant resistance 8K2 | 000 (Contatto pulito) | 000 (Contatto pulito) | 000 (Contatto pulito) | 000 (Contatto pulito) | |
| P017 | INPUT_1 operating selection | <ul style="list-style-type: none"> • 000: NONE (unused parameter) • 001: START (start) | 000 (START) | 000 (START) | 000 (START) | 000 (START) | |
| P018 | INPUT_2 operating selection | <ul style="list-style-type: none"> • 002: PED. (pedestrian) • 003: OPEN (separated open) • 004: CLOSE (separated close) | 002 (PEDESTRIAN) | 002 (PEDESTRIAN) | 000 (PHOTO 1) | 000 (PHOTO 1) | |
| P019 | INPUT_3 operating selection | <ul style="list-style-type: none"> • 005: OPEN_PM (man present open) • 006: CLOSE_PM (man present close) | 010 (SAFETY) | 010 (SAFETY) | 010 (SAFETY) | 010 (SAFETY) | |
| P020 | INPUT_4 operating selection | <ul style="list-style-type: none"> • 007: ELOCK-IN (electric-lock activation. See P062) • 008: PHOTO 1 (photocell 1) • 009: PHOTO 2 (photocell 2) | 010 (SAFETY) | 000 (PHOTO 1) | 010 (SAFETY) | 010 (SAFETY) | |
| P021 | INPUT_5 operating selection | <ul style="list-style-type: none"> • 010: SAFETY (safety rib) • 011: STOP (lock) | 000 (PHOTO 1) | 000 (PHOTO 1) | 011 (STOP) | 000 (OPEN) | |
| P022 | INPUT_6 operating selection | <ul style="list-style-type: none"> • 012: FCA1 (opening limit switches Mot1) • 013: FCA2 (opening limit switches Mot2) • 014: FCC1 (closing limit switches Mot1) • 015: FCC2 (closing limit switches Mot2) | 012 (FCA 1) | 000 (PHOTO 2) | 000 (NONE) | 004 (CLOSE) | |
| P023 | Allocation of CHANNEL 1 of remotes | <ul style="list-style-type: none"> • 000: NONE (unused parameter) • 001: START (start) | 000 (START) | 000 (START) | 000 (START) | 000 (START) | |
| P024 | Allocation of CHANNEL 2 of remotes | <ul style="list-style-type: none"> • 002: PEDESTRIAN (pedestrian) • 003: OPEN (separated open) | 000 (NONE) | 000 (NONE) | 000 (NONE) | 000 (NONE) | |
| P025 | Allocation of CHANNEL 3 of remotes | <ul style="list-style-type: none"> • 004: CLOSED (separated close) • 005: OPEN_PM (man present open) • 006: CLOSED_PM (man present close) | 000 (NONE) | 000 (NONE) | 000 (NONE) | 000 (NONE) | |
| P026 | Allocation of CHANNEL 4 of remotes | <ul style="list-style-type: none"> • 007: ELOCK-IN (attivazione elettroserratura. Vedi P062) | 000 (NONE) | 000 (NONE) | 000 (NONE) | 000 (NONE) | |
| P027 | Selection of type of remotes | <ul style="list-style-type: none"> • 000: HCS fix-code • 001: HCS rolling-code • 002: Dip-switch | 000 | 000 | 000 | 000 | |

INPUTS CONFIGURATION PARAMETERS

Unused Parameter

| OPERATORS CONFIGURATION PARAMETERS | | OPERATING PARAMETERS | | def0 sliding gate | def1 Swing gate | def2 overhead door | def3 barriers | def4 Sectional doors |
|------------------------------------|--|--|--|-------------------|-----------------|--------------------|---------------|----------------------|
| PQ28 | Selection type of operators | <ul style="list-style-type: none"> • 001: LOOK / MAC • 002: GHOST • 003: LVI 500/502 / 902 / LATO / PASS | <ul style="list-style-type: none"> • 004: STOP • 005: LVI 6RR • 006: LVI 9RR • 007: GULLIVER / REV | 005 | 001 | 003 | 004 | |
| PQ29 | Selected work with or without encoders. WARNING: PQ29 must be set correctly before performing the procedure for programming | <ul style="list-style-type: none"> • 000: motors with encoder • 001: engines without encoder | | 000 | 001 | 000 | 000 | |
| PQ30 | Selecting operators number | <ul style="list-style-type: none"> • 001: one operator • 002: two operators | | 001 | 002 | 001 | 001 | |
| PQ31 | Unused parameter | | | | | | | |
| PQ32 | Operators speed adjustment during the stroke while opening | 15%tot.....100%tot | | 100 | 100 | 100 | 100 | |
| PQ33 | Operators speed adjustment during the stroke while closing | 15%tot.....100%tot | | 100 | 100 | 100 | 100 | |
| PQ34 | Operators speed adjustment during slow-down while opening and closing | 15%tot.....100%tot | | 040 | 050 | 050 | 030 | |
| PQ35 | Slow down duration adjustment while opening | 5%tot.....80%to | | 025 | 020 | 020 | 030 | |
| PQ36 | Slow down duration adjustment while closing | 5%tot.....80%tot | | 025 | 020 | 020 | 030 | |
| PQ37 | Operator 1 force adjustment while opening (if = 100% obstacle detection deactivated) | 15%tot.....100%tot | | 050 | 050 | 050 | 099 | |
| PQ38 | Operator n.1 force adjustment while closing (if = 100% obstacle detection deactivated) | 15%tot.....100%tot | | 050 | 050 | 050 | 099 | |
| PQ39 | Operator n.2 force adjustment while opening (if = 100% obstacle detection deactivated) | 15%tot.....100%tot | | 050 | 050 | / | 099 | |
| PQ40 | Operator n.2 force adjustment while closing (if = 100% obstacle detection deactivated) | 15%tot.....100%tot | | 050 | 050 | / | 099 | |
| PQ41 | Automatic closing times adjustment (if = 0 automatic closing deactivated) | 0sec.....255sec | | 000 | 000 | 000 | 000 | |
| PQ42 | Pedestrian automatic closing time adjustment (se = 0 pedestrian automatic closing deactivated) | 0sec.....255sec | | 000 | 000 | 000 | 000 | |
| PQ43 | Pedestrian stroke duration adjustment | 5%tot.....100%tot | | 030 | 035 | 035 | 100 | |
| PQ44 | Pre-flashing time adjustment | 0sec.....10sec | | 000 | 000 | 000 | 000 | |
| PQ45 | Adjustment of phase displacement time while opening | 0sec.....30sec | | / | 001 | / | / | |
| PQ46 | Adjustment of phase displacement time while closing | 0sec.....30sec | | / | 003 | / | / | |
| PQ47 | Collectivity function: if it is activated it deactivates both opening and closing inputs for the whole duration of automatic opening and closing | <ul style="list-style-type: none"> • 000: "collectivity function" deactivated • 001: "collectivity function" activated | | 000 | 000 | 000 | 000 | |
| PQ48 | Ram blow function: it pushes the motors closed for one second before each opening movement, so as to ease the electric-lock release | <ul style="list-style-type: none"> • 000: "ram blow" deactivated • 001: "ram blow function" activated | | 000 | 000 | 000 | 000 | |
| PQ49 | "Reversal" mode selection (during the manoeuvre a command impulse reverse the movement) or "step by step" (during the manoeuvre a command impulse stops the movement). A next impulse restart the operator to the opposite direction. | <ul style="list-style-type: none"> • 000: "reversal function" • 001: "step by step function" | | 001 | 000 | 000 | 000 | |
| PQ50 | PHOTO 1 PHOTO input functioning: if=0 photocells are enabled while closing and at start when gate is closed; if=1 photocells are always enabled; if=2 photocells are enabled while closing only. When enabled, its activation provokes: the inversion (while closing), the stop (while opening) and prevent the starting (when gate is closed). | <ul style="list-style-type: none"> • 000: photocells enabled while closing and at gate closed • 001: photocells always enabled • 002: photocells enabled only while closing • 003: as 000 but with "close immediately" enabled • 004: as 001 but with "close immediately" enabled • 005: As 002 but with "close immediately" enabled | | 002 | 002 | 002 | 002 | |
| PQ51 | PHOTO 2 If=3-4-5, the operation is the same as the values 0-1-2 but with "close immediately" enabled: in any case, during the opening and/or the pause time, removal of a possible obstacle causes the gate automatically closes after a fixed delay of 3 sec. | | | 000 | 001 | 002 | 002 | |
| PQ52 | Operation mode selection of the warning light output: If = 0 "warning light" (output always ON when the gate is open, OFF after a closing operation), If > 1 "courtesy light" (output ON during each movement, OFF when the motor stops, after the setting delay). | <ul style="list-style-type: none"> • 000: "fix warning light" • >001: "courtesy light" off delay (1sec.....255sec) | | 001 | 001 | 060 | 001 | |

| | | def0 sliding gate | def1 Swing gate | def2 overhead door | def3 barriers | def4 Sectional doors |
|------|---|----------------------|--------------------|-----------------------|------------------|-------------------------|
| P053 | Searches for end of stroke while opening too: when activated, operators stop only at their arrival at the end of stroke, also while opening. | / | 000 | 000 | 001 | |
| P054 | "soft start" function: motors accelerate gradually until they reach the set speed, avoiding sudden departures | 001 | 001 | 001 | 001 | |
| P055 | Adjust the inversion on obstacle period (detected by internal anti-crushing sensor or by the safety input when activated): if = 0 it makes a complete inversion, if > 0 indicates the duration (in seconds) of the run, after inversion resulting from detection of an obstacle during the opening. | 000 | 000 | 000 | 000 | |
| P056 | Adjust the inversion on obstacle period (detected by internal anti-crushing sensor or by the safety input when activated): if = 0 it makes a complete inversion, if > 0 indicates the duration (in seconds) of the run, after inversion resulting from detection of an obstacle during the closing. | 000 | 000 | 000 | 000 | |
| P057 | Facilitating manual release: If≠0, after detecting the locking stop, the engine reverses for a brief time to release the pressure on it, and thus facilitate the manual release. The set value shows the length of the inversion. If=0 function disabled | 000 | 003 | 003 | 002 | |
| P058 | Margin adjustment of the opening stroke: adjusts the duration of the last stretch of the race during which any obstacle is interpreted as a stroke, stopping the operator without executing the inversion. The value set indicates the number of revolutions of the rotor. | / | 025 | 025 | 020 | |
| P059 | Margin adjustment of the closing stroke: adjust the duration of the last stretch of the race during which any obstacle is interpreted as a stroke, stopping the operator without executing the inversion. The value set indicates the number of revolutions of the rotor. | / | 025 | 025 | 020 | |
| P060 | Operators force adjustment at stroke arrival - If = 0, setting off (the force value on the stroke is calculated automatically) - If ≠ 0, indicates the value (expressed in% of the max value) of the force exerted on the stroke. | / | 000 | 000 | 000 | |
| P061 | Unused parameter | | | | | |
| P062 | Electric-lock operating: if =0 electric-lock art. 110, if= 1 24V output commanded by ELOCK_IN input in impulsive mode, if=2 24V output commanded by ELOCK_IN input in step-by-step mode, if=3 24V output for piloting the electrobrake on REV sliding operator, if>3 24V output commanded by ELOCK_IN input in temporized mode (the set value indicates the delay of turning off expressed in sec. | 000 | 000 | 000 | 000 | |
| P063 | Run direction inversion: If=1 automatically reverses the outputs open/close of the operators and any opening/closing limit switches inputs, avoiding having to manual change the wiring when installing the operator in an inverted position. | 000 | 000 | 000 | 000 | |
| P064 | Multipier operations-counter: Multiply the number of operations after which the total operations-counter will be updated. To view the values, refer to the section "Visualisation of inputs and operations-counter status". | 001 | 001 | 001 | 001 | |
| P065 | Maintenance Operations-counter: if = 0 reset the counter and disables the intervention request , if> 0 indicates the number of operations (x 500) to be made before the control panel executes a 4 second additional pre-flash to indicate the need of maintenance. i.g.: If P064 = 050, operations number = 50x500 = 25000 operations Warning: Before you set a new value of the counter-manoevres maintenance, the same must be reset by setting P065 = 0 and only later P065 = "new value". | 000 | 000 | 000 | 000 | |
| P066 | Selection of operating flashing light output: If=0 intermittent flashing light output; If=1 Fixed flashing light output (for flashing lights with intermittent interior circuits). | 001 | 001 | 001 | 001 | |
| P067 | Unused parameter | | | | | |
| P068 | Unused parameter | | | | | |
| P069 | Unused parameter | | | | | |
| P070 | Unused parameter | | | | | |
| | | | | | | Unused Parameter |

OPERATING PARAMETERS

6 MESSAGES SHOWN ON THE DISPLAY

| WORKING STATUS MESSAGES | | |
|-------------------------|--|---|
| Mess. | Description | |
| ---- | Gate is closed | |
| JL | Gate is opened | |
| OPEN | Opening under way | |
| CLOS | Closing under way | |
| STEP | While in step-by-step mode, the control board awaits further instructions after a start command | |
| BLOC | Stop command received | |
| rESP | Reset current position: The control unit has just been turned on after a power failure, or the gate has exceeded the maximum number (50) of inversions allowed without ever getting to the closing stroke, or the maximum number (3) of consecutive operations allowed of the anti-crushing device. Once the control unit has been reset and open command given the gate will start moving at slow speed, until it reaches end of travel. At this stage any start pulses are ignored. | |
| ERROR MESSAGES | | |
| Mess. | Description | Possible solutions |
| ErrP | Error position: The reset position procedure is not successful. The control panel is awaiting commands. | <ul style="list-style-type: none"> - Make sure there are no specific frictions and / or obstacles during the run; - Give a start pulse to initiate a position reset procedure; - Verify that the operation is completed successfully, manually helping the run, if necessary; - Adjust power and speed settings if necessary. |
| Err3 | External photocells and/or safety devices are activated or out of order. | <ul style="list-style-type: none"> - Make sure that all safety devices and/or photocells installed are working properly. |
| Err4 | Possible failure to the control board power circuit. | <ul style="list-style-type: none"> - Disconnect and connect power supply. Give a start impulse, if this error appears again, replace the control board. |
| Err5 | Time-out operators run: The engine/s exceeded the maximum operating time (5min) without ever stopping. | <ul style="list-style-type: none"> - Give a start pulse to start the position reset procedure; - Ensure that this operation is successful. |
| Err6 | Time-out obstacle detection: With anti-crushing sensor disabled, was still detected the presence of an obstacle that prevents movement of the leaf for a period of 10 seconds more. | <ul style="list-style-type: none"> - Make sure there are no specific frictions and / or obstacles during the run; - Give a start pulse to initiate a position reset procedure; - Verify that the operation is completed successfully. |
| Err7 | Operators movement not detected. | <ul style="list-style-type: none"> - Make sure that operators and encoders connections are well done. - Check the setting of parameter P029 (Motor selection with or without encoder) and make sure it is correct. - If this error appears again, replace the control panel. |

7 INSTALLATION TEST

The testing operation is essential in order to verify the correct installation of the system. **DEA** System wants to summarize the proper testing of all the automation in 4 easy steps:

- Make sure that you comply strictly as described in paragraph 2 "WARNINGS SUMMARY";
- Test the opening and closing making sure that the movement of the leaf match as expected. We suggest in this regard to perform various tests to assess the smoothness of the gate and defects in assembly or adjustment;
- Ensure that all safety devices connected work properly;
- Perform the measurement of impact forces in accordance with the standard 12445 to find the setting that ensures compliance with the limits set by the standard EN12453.

8 PRODUCT DISPOSAL



WARNING In compliance with EU Directive 2002/96/EC on waste electrical and electronic equipment (WEEE), this electrical product should not be treated as municipal mixed waste. Please dispose of the product and bring it to the collection for an appropriate local municipal recycling.

Questo manuale è stato realizzato utilizzando carta ecologica riciclata certificata Ecolabel per contribuire alla salvaguardia dell'ambiente.

This manual was printed using recycled paper certified Ecolabel to help save the environment.

Ce manuel a été réalisé en utilisant du papier recyclé certifié Ecolabel afin de respecter l'environnement.

El manual ha sido fabricado utilizando papel reciclado certificado Ecolabel para preservar el medio ambiente.

Este manual foi impresso com papel reciclado certificado Ecolabel para ajudar a preservar o meio ambiente.

W celu wsparcia ochrony środowiska, niniejszą instrukcję zrealizowaliśmy wykorzystując papier ekologiczny pochodzący z recyklingu i posiadający certyfikat Ecolabel.

